

ART.	 LIFT TABLE	N mm	O mm	P mm	Q mm
832/SP • 834	2500 Kg	80	360	1400	2000

ART. 830 • 834

MODELLI A PEDANE PIANE
MODELS WITH FLAT PLATFORMS
MODELES AVEC CHEMINS DE ROULEMENT NUS
MODELLE MIT FLACHEN FAHRSCHIENEN

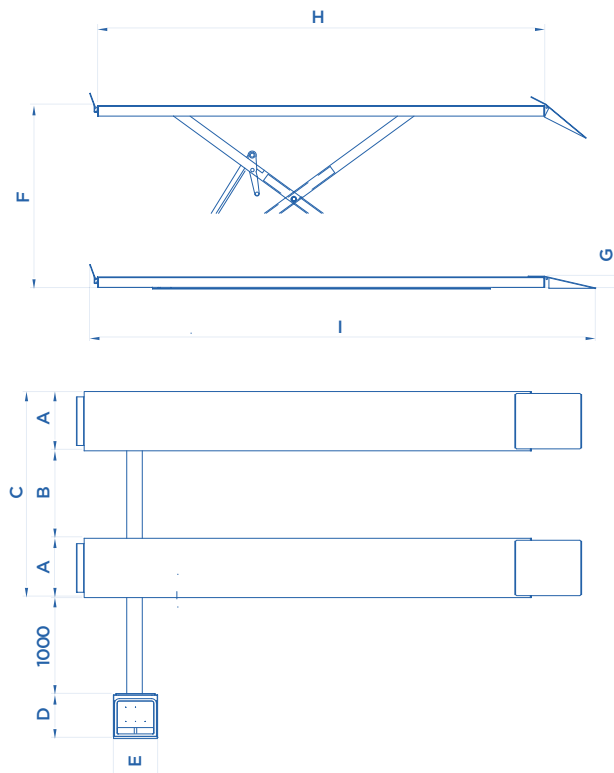

ART. 831/SP • 832/SP

MODELLI PER ASSETTO RUOTE
WHEEL ALIGNMENT MODELS
MODELES POUR GEOMETRIE ROUES
MODELLE GEEIGNET ZUR ACHSVERMESSUNG

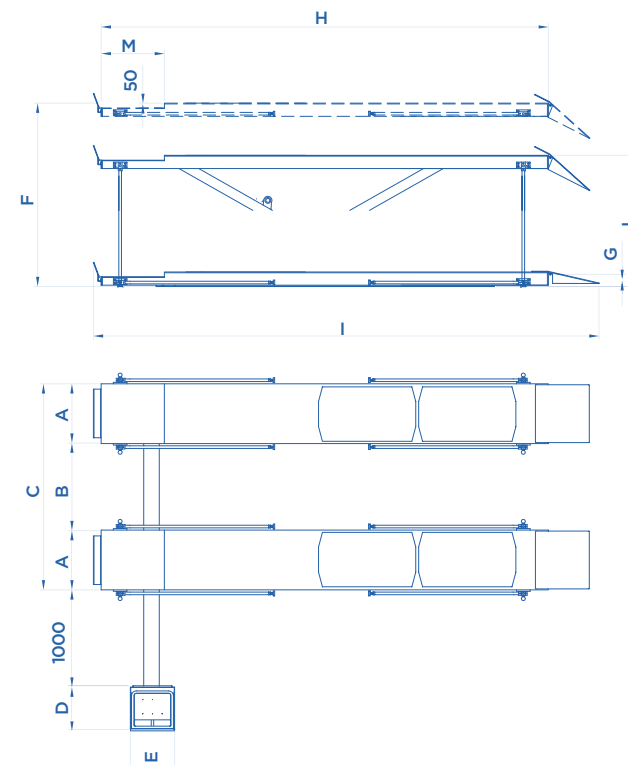

ART.			Motore trifase Three-phase motor Moteur triphasé Netzspannung	A mm	B mm	C mm	D mm	E mm	F mm	G mm	H mm	I mm	L mm	M mm	
830				610	900	2120	460	450	1920	150	4600	5200			1910
831/SP	3600 Kg	3,3 KW	400V • 50HZ	610	900	2120	460	450	1920	150	4600	5200	1350	650	2010
832/SP				610	900	2120	460	450	1920	150	4600	5200	1350	650	2260
834				610	900	2120	460	450	1920	150	4600	5200			2200