

Modello a pavimento  
Floored model  
Modèle au sol  
Überflur-Modell

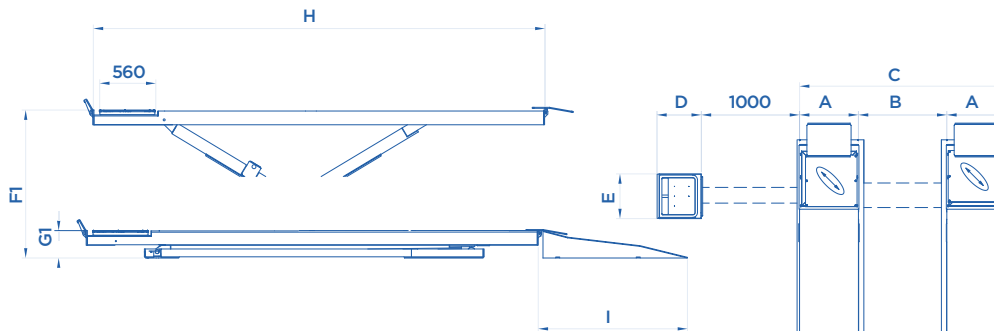

Modello a scomparsa  
Disappearing model  
Modèle encastrable  
Unterflur-Modell

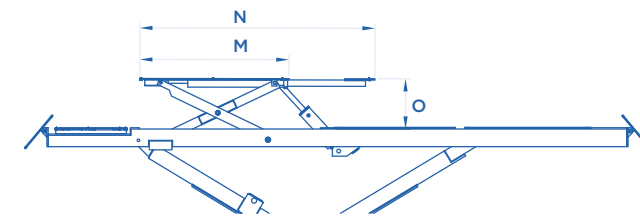
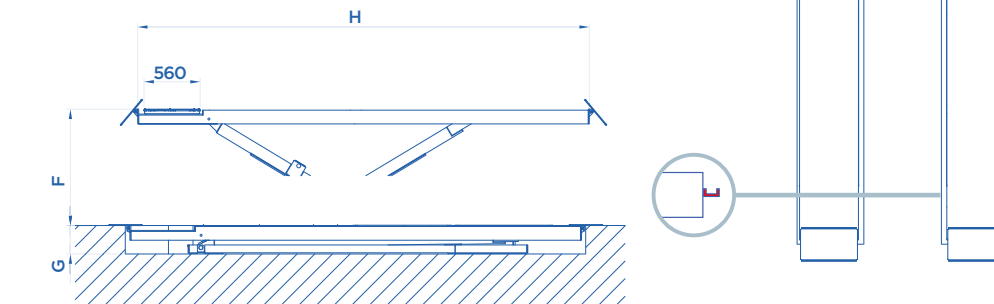

ART.	LIFT TABLE	M mm	N mm	O mm
825 • 825/I	3000 Kg	1420	1870	400
805 • 815	4000 Kg	1465	2000	400

ART.	LIFT TABLE	Motor icon	Motore trifase Three-phase motor Moteur triphasé Netzspannung	A mm	B mm	C mm	D mm	E mm	F mm	F1 mm	G mm	G1 mm	H mm	I mm	KG
<b>840</b> <b>840/I</b>	3500 Kg	4 KW	400V • 50HZ	650 650	900 900	2200 2200	460 460	450 450		1880	290	280	5100 5100	1500	1900 1750
<b>825</b> <b>825+853/A</b> <b>825/I</b> <b>825/I+853/A</b> <b>826</b> <b>826+853/A</b> <b>826/I</b> <b>826/I+853/A</b>	4000 Kg	3,3 KW	400V • 50HZ	600 600 600 600 600 600 600 600	900 900 900 900 900 900 900 900	2100 2100 2100 2100 2100 2100 2100 2100	460 460 460 460 460 460 460 460	450 450 450 450 450 450 450 450		1880 1880 1800 1800 1880 1880 1800 1800	290 290 290 290	280 280 280 280	4600 4600 4600 4600 4600 4600 4600 4600	1500 1500 1500 1500 1500 1500 1500 1500	2490 2540 2200 2250 2100 2150 1850 1900
<b>805</b> <b>805+853/B</b> <b>815</b> <b>815+853/B</b> <b>805/A</b> <b>805/A+853/B</b> <b>815/A</b> <b>815/A+853/B</b>	5000 Kg	4 KW	400V • 50HZ	650 650 650 650 650 650 650 650	900 900 900 900 900 900 900 900	2200 2200 2200 2200 2200 2200 2200 2200	500 500 500 500 500 500 500 500	550 550 1800 1800 1800 1800 1800 1800		1880 1880 290 290 1880 1880 290 290	280 280 290 290	280 280	4900 4900 4900 4900 4900 4900 4900 4900	1500 1500 1500 1500 1500 1500 1500 1500	3040 3110 2750 2820 2480 2550 2230 2300

Sollevatori per linee di revisione B=800 mm

⚙️ Potenza motore • Motor power • Puissance moteur • Motorleistung