

ART. 199/DK • 199/GK

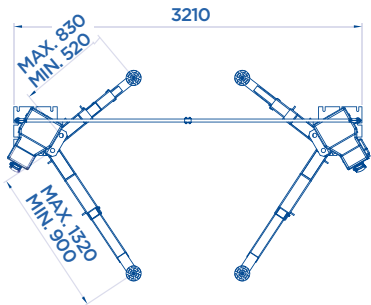

2800  
3200 **KG**

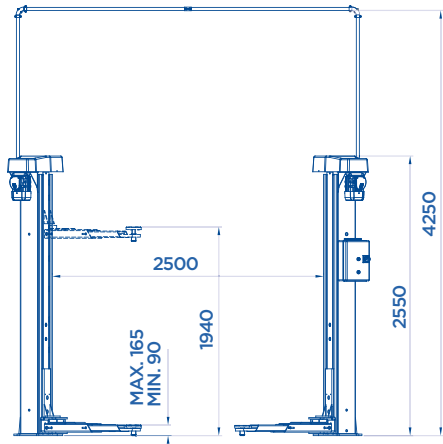

**OPTIONAL** Pag. 025

ART.



Motore trifase  
Three-phase motor  
Moteur triphasé  
Netzspannung



<b>199/DK</b>	2800 Kg	1,5+1,5 KW	400V • 50HZ	720
<b>199/GK</b>	3200 Kg	2+2 KW	400V • 50HZ	760

Potenza motore • Motor power • Puissance moteur • Motorleistung